

Industrial Grade **TURBINE HOUSING** Owner's Manual

Includes Stainless Steel Housings with
Tri-Clover[®] Flange Fittings

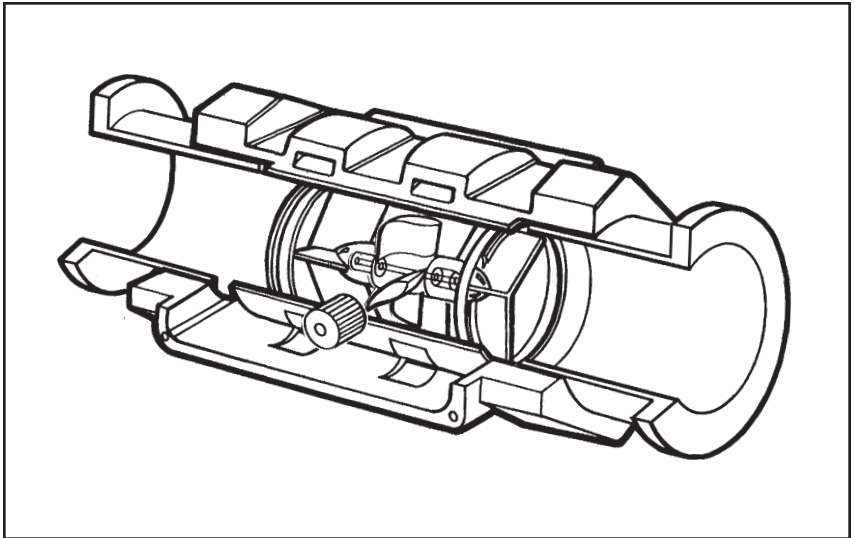

To the owner...

Congratulations on receiving your GPI Industrial Grade Turbine. We are pleased to provide you with a product designed to give you maximum reliability and efficiency.

Our business is the design, manufacture, and marketing of liquid handling, agricultural, and recreational products. We succeed because we provide customers with innovative, reliable, safe, timely, and competitively-priced products. We pride ourselves in conducting our business with integrity and professionalism.

We are proud to provide you with a quality product and the support you need to obtain years of safe, dependable service.



Victor Lukic, President
Great Plains Industries, Inc.

GENERAL INFORMATION

This manual will assist you in installing and maintaining your GPI Industrial Grade turbine housing. (See Figure 1) Information on computer electronics and accessory modules are contained in other manuals. Please reference those as necessary.

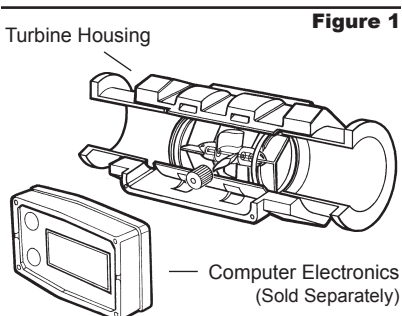

Figure 1

TABLE OF CONTENTS

General Information.....	2
Installation	4
Operation.....	5
Maintenance	5
Troubleshooting.....	7
Model Number Chart	8
Specifications	8
Illustrated Parts Drawing	10
Service.....	11

For best results, take the time to fully acquaint yourself with all information about all components of your GPI Electronic Digital Metering System prior to installation and use. If you need assistance, contact the distributor from whom you purchased your turbine.



This symbol is used throughout the manual to call your attention to safety messages.

WARNING

Warnings alert you to the potential for personal injury.

CAUTION

Cautions call your attention to practices or procedures which may damage your equipment.

Notes give information that can improve efficiency of operations.

It is your responsibility to make sure that all operators have access to adequate instructions about safe operating and maintenance procedures.

Read Me!

For your safety, review the major warnings and cautions below before operating your equipment.

WARNING

The apparatus enclosure may contain aluminum and is considered to constitute a potential risk of ignition by impact or friction. Care must be taken into account during installation and use to prevent impact or friction.

WARNING

Part of the enclosure is constructed from plastic. To prevent the risk of electrostatic sparking the plastic surface should only be cleaned with a damp cloth.

1. Use **only fluids** that are compatible with the housing material and the wetted components of your turbine.

NOTE: Models 1/2 inch, 3/4 inch and 1 inch are tested with solvent test fluid at the factory. Clean before using in sensitive areas.

2. When measuring flammable liquids, observe precautions against fire or explosion.
3. When handling hazardous liquids, always follow the liquid manufacturer's safety precautions.
4. When working in hazardous environments, always exercise appropriate safety precautions.

5. Always dispose of used cleaning solvents in a safe manner according to the solvent manufacturer's instructions.

6. During turbine removal, liquid may spill. Follow the liquid manufacturer's safety precautions for clean up of minor spills.

7. Do not blow compressed air through the turbine.

8. Do not allow liquids to dry inside the turbine.

9. Handle the rotor carefully. Even small scratches or nicks can affect accuracy.

10. For best results, always verify accuracy before use.

Product Description

GPI Industrial Meter Turbines are identified by the internal diameter of the inlet and outlet.

Model S05T – 1/2 inch

Model S07T – 3/4 inch

Model S10T – 1 inch

Model S15T – 1-1/2 inch

Model S20T – 2 inch

NOTE: Size refers to turbine size, not the outside diameter of ferrule or clamp size.

Each turbine is designed to work with on-board computer electronics and/or with one of several accessory output modules.

Liquid flows through the turbine housing causing an internal rotor to spin. As the rotor spins, an electrical signal is generated in the pickup coil. This signal is converted into engineering units (gallons, litres, etc.) on the local display. Accessory modules can be used to export the signal to other equipment.

Upon receipt, examine your meter for visible damage. The turbine is a precision measuring instrument and should be handled as such. Remove the protective caps for a thorough inspection. If any items are damaged or missing, contact your distributor.

Make sure the turbine model meets your specific needs. Refer to the Specifications Section and confirm the following:

1. The flowrate is within the limits of your model.
2. The liquid is compatible with the turbine's wetted components.
3. The system's pressure does not exceed the turbine's maximum pressure rating.

Information specific to your particular turbine, including the serial number is etched on the meter body. Be prepared to provide this information if you call customer support.

For your future reference, it might be useful to record this information in the manual in case it becomes unreadable on the turbine.

INSTALLATION

All GPI turbines are designed to measure flow in only one direction. The direction is indicated by the arrow, cast-molded in the turbine. If the computer display is upside down, remove the four screws, turn the display 180 degrees and reinstall the screws. See Diagram 1.

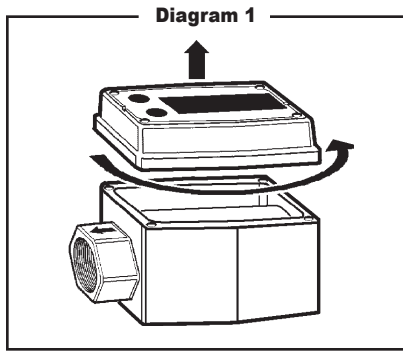

Flow altering devices such as elbows, valves, and reducers can affect accuracy. See Diagram 2. The following recommended guidelines are given to enhance accuracy and maximize performance. Distances given here are minimum requirements; double them for desired straight pipe lengths.

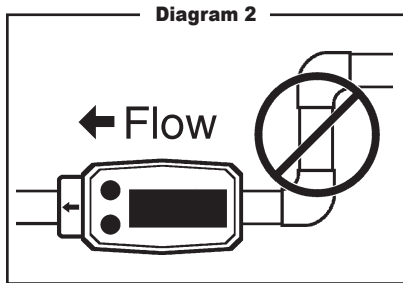

Upstream from the turbine, allow a minimum straight pipe length at least 10 times the internal diameter of the turbine. For example, with the 1 inch turbine, there should be 10 inches (25.4 cm) of straight pipe immediately upstream. The desired upstream straight pipe length is 20 inches (50.8 cm).

Downstream from the turbine, allow a minimum straight pipe length at least 5 times the internal diameter of your turbine. For example, with the 1 inch turbine, there should be 5 inches (12.7 cm) of straight pipe immediately downstream. The desired downstream distance is 10 inches (25.4 cm).

Diagram 3

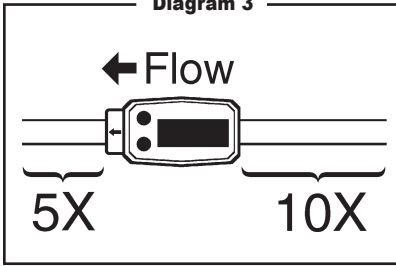

A typical back pressure of 5 to 50 PSI (0.34 to 3.4 bar) will prevent cavitation. Create back pressure by installing a control valve on the downstream side of the meter at the proper distance detailed above.

Foreign material in the liquid being measured can clog the turbine's rotor and adversely affect accuracy. If this problem is anticipated or experienced, install screens to filter impurities from incoming liquids.

Models 1/2 inch, 3/4 inch and 1 inch:

Maximum Particulate Size	
Inches:	0.005
Microns:	125
Mesh:	120
Standard Sieve:	125 μ m
Alternative Sieve:	No. 120

Models 1-1/2 inch and 2 inch:

Maximum Particulate Size	
Inches:	0.018
Microns:	500
Mesh:	35
Standard Sieve:	500 μ m
Alternative Sieve:	No. 35

To ensure accurate measurement, remove all air from the system before use.

Each turbine contains a removable back coverplate. Leave the coverplate installed unless accessory modules specify removal.

Connections

1. Make sure the arrow on the outlet is pointed in the direction of the flow.
2. Insert a gasket between the meter fitting and the mating fitting. Determine the gasket material based on the operating conditions and the type of fluid used.
3. Fasten with the appropriate clamp. Tighten clamp to manufacturer's specifications.

Verify accuracy after connections are complete. See Operation section.

OPERATION

Verify Accuracy

Before use, check the turbine's accuracy and verify calibration.

1. Make sure there is no air in the system.
2. Measure an exact known volume into an accurate container.
3. Verify the volume against the readout or recording equipment.

NOTE: If necessary, use a correction factor to figure final volume.

For best results, accuracy should be verified periodically as part of a routine maintenance schedule.

MAINTENANCE

Remove the Turbine

⚠ WARNING

During turbine removal, liquid may spill. Follow the liquid manufacturer's safety precautions for clean up of minor spills.

1. Drain all liquid from the turbine. Wear protective clothing as necessary.
2. Disconnect both ends of the turbine.
3. If the turbine is not immediately installed again, cap lines as necessary.

Clean the Turbine

During use, the turbine should be kept full of liquid to ensure that drying does not occur inside the turbine. If drying or caking should occur, the rotor will stick or drag, affecting accuracy. To determine if the rotor is stuck or dragging, gently blow air through the meter and listen for the quiet whir of the rotor.

⚠ CAUTION

Never blow compressed air through the meter. It could damage the rotor.

1. Remove the turbine from the system following the directions above.
2. Carefully clean residue off all parts. Remove internal parts as detailed above. Note orientation carefully for correct assembly. Internal parts can be soaked for 10 to 15 minutes in compatible cleaning solutions. Use a soft brush or small probe to *carefully* remove residue from the rotor.

⚠ WARNING

Follow the liquid manufacturer's instructions for the disposal of contaminated cleaning solvents.

3. When the rotor turns freely, assemble and install it again following the instructions above.

4. Check accuracy after cleaning. See Diagram 4 for example of bucket test method.

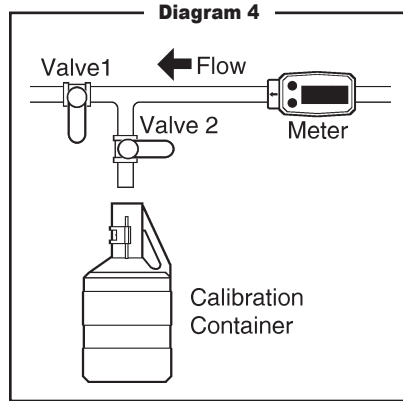

Replace Internal Parts

1. Remove the turbine from the system as detailed above.

NOTE: Note the orientation of all internal parts as they are removed, especially the orientation of the rotor to the flow direction arrow. See Figure 2.

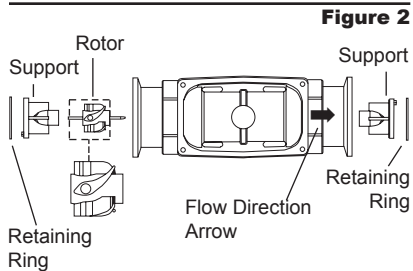

2. Using a small tool such as a screwdriver or awl, gently pry one retaining ring from its groove. Remove the support. If necessary, use needle nose pliers. Little or no force should be required.
3. Carefully remove the rotor.

⚠ CAUTION

Handle the rotor carefully. Even small scratches or nicks can affect accuracy.

4. Turn the turbine over and remove the other retaining ring. Remove the other support.
5. Clean, as detailed below, or discard as necessary.
6. Replace one support and retaining ring. Parts should drop easily into place with little or no force.
7. Install the rotor. Make sure the wide end of the rotor's blades faces the flow direction. See Figure 3.

Figure 3

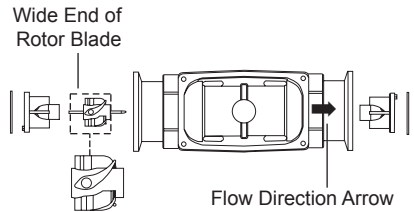

8. Turn the turbine over and drop the second turbine support into place. Put the final retaining ring into position.
9. Reinstall the turbine, purge the system of air, and verify accuracy before use.

TROUBLESHOOTING

Symptom	Probable Cause	Solution
A. MEASUREMENT IS NOT ACCURATE	1. Turbine operated below minimum rate	Increase flowrate. See Specifications.
	2. Turbine partially clogged with dried liquid	Remove turbine. Clean carefully. Make sure rotor spins freely.
	3. Turbine bearings partially clogged with dried liquid	Remove turbine. Clean carefully. Make sure rotor spins freely.
	4. Sealant wrapped around rotor	Remove turbine. Clear material from rotor. Make sure rotor spins freely.
	5. Installed too close to fittings	Install correctly. See Installation Section.
	6. Improper connections to recording device	Check all electrical connections. Reference appropriate installation instructions.
	7. Accuracy needs verification	Complete normal accuracy verification procedures. Repeat periodically.

MODEL NUMBER CHART

Normal Range GPM Water	Normal Range LPM Water	Inlet/Outlet Size	Stainless Steel
1 - 10	3.8 - 37.9	1/2 inch	S05T
2 - 20	7.6 - 75.7	3/4 inch	S07T
5 - 50	18.9 - 190	1 inch	S10T
10 - 100	38 - 380	1-1/2 inch	S15T
20 - 200	76 - 760	2 inch	S20T

SPECIFICATIONS

All data on Models 1/2 inch, 3/4 inch and 1 inch determined with 1 centipoise solvent test fluid at 70° F (21° C). Data on Models 1-1/2 inch and 2 inch is determined with water at 70° F (21° C). Size refers to the size of the turbine, not the body ferrule. Refer to dimension chart for detail sizes.

Models Size	S05T 1/2 in.	S07T 3/4 in.	S10T 1 in.	S15T 1-1/2 in.	S20T 2 in.
Linear Flow Range Gallons/minute (GPM) Litres/minute (LPM)	1 - 10 3.8 - 37.9	2 - 20 7.6 - 75.7	5 - 50 18.9 - 190	10 - 100 38 - 380	20 - 200 76 - 760
Maximum Flow ¹ Gallons/minute (GPM) Litres/minute (LPM)	15 56.8	30 113.6	75 284	150 568	300 1,136
Maximum Pressure Drop in 10:1 Range PSIG bar	8 0.55	7.5 0.5	5 0.34	4 0.28	4 0.28
Frequency Range in Linear Flow Range (Hz)	45 - 450	37 - 370	45 - 475	35 - 350	33 - 330
Inlet/Outlet Size	1/2 in.	3/4 in.	1 in.	1-1/2 in.	2 in.
Fitting/Clamp Size	3/4 in.	1 in.	1-1/2 in.	2 in.	2-1/2 in.
Weight † Pounds Kilograms	1.8 lbs 0.8 kg	2.2 lbs 1.0 kg	2.5 lbs 1.2 kg	4.0 lbs 1.8 kg	5.8 lbs 2.6 kg

† Computer electronics add 0.2 lbs. (0.1 kg) to total weight.

¹ The meter can operate up to this flowrate without damage. Continuous operation will severely degrade meter life and performance.

Performance

Linear Range for 1/2 in.:	10:1 @ ±2.0% of reading
Linear Range for 3/4 in. and 1 in.:	10:1 @ ±1.5% of reading
Linear Range for 1-1/2 in. and 2 in.:	10:1 @ ±1.0% of reading
Repeatability:	± 0.1%

Pressure Rating 450 PSIG (31 bar) @ 70° F with Type 1 Buna-N Gasket

Wetted Components

Housing:	316 Stainless Steel
Journal Bearings:	Ceramic (96% Alumina)
Shaft:	Tungsten Carbide
Rotor and Supports:	PVDF
Retaining Rings:	316 Stainless Steel

Temperature Range -40° F to +250° F (-40° C to +121° C)

These temperatures apply to operations and storage. They are only for the turbine without computer electronics. Final operational temperature range is determined by computer electronics or accessory modules.

Dimensions

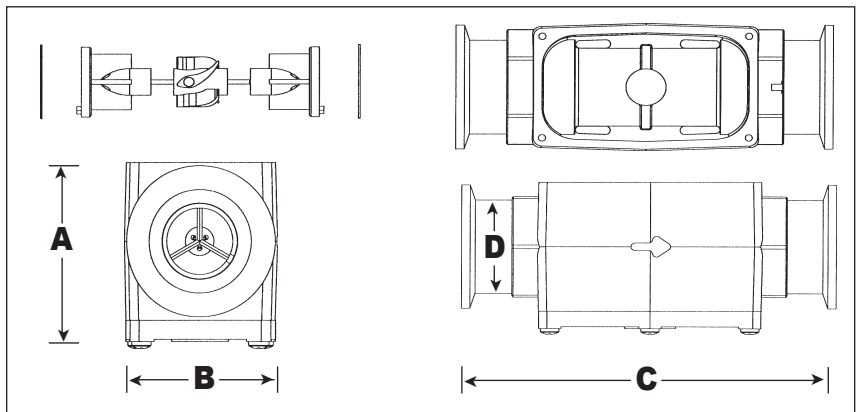

Models Size	S05T 1/2 in.	S07T 3/4 in.	S10T 1 in.	S15T 1-1/2 in.	S20T 2 in.
A = Height					
Inches	1.8 in.	2.0 in.	2.2 in.	2.8 in.	3.2 in.
Centimeters	4.6 cm	5.1 cm	5.6 cm	7.1 cm	8.2 cm
B = Width					
Inches	2.0 in.	2.0 in.	2.0 in.	2.7 in.	3.3 in.
Centimeters	5.1 cm	5.1 cm	5.1 cm	6.9 cm	8.4 cm
C = Length					
Inches	5.0 in.	5.0 in.	5.5 in.	6.5 in.	7.0 in.
Centimeters	12.71 cm	12.71 cm	13.97 cm	16.51 cm	17.78 cm
D = Outside Dia. - Ferrule					
Inches	.75 in.	1.00 in.	1.50 in.	2.00 in.	2.50 in.
Centimeters	1.90 cm	2.54 cm	3.81 cm	5.08 cm	6.35 cm
Fitting/Clamp Size	3/4 in.	1 in.	1-1/2 in.	2 in.	2-1/2 in.

Computer electronics add 0.7 in. (1.8 cm) to height of turbine.

ILLUSTRATED PARTS DRAWING

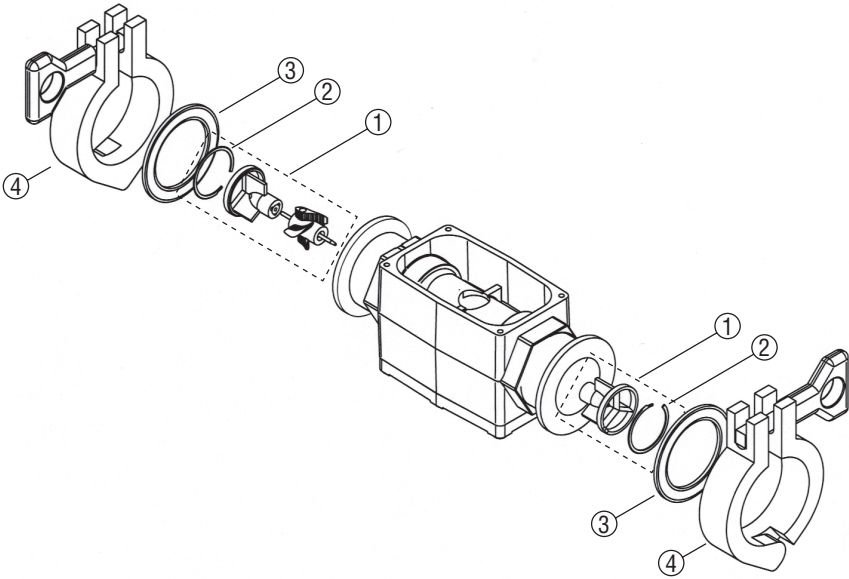

Item No.	Part No.	Description	No. Req'd.
	901002-52	Computer Assembly Seal (not shown)	1
1	125500-1	1/2 inch Rotor/Support Replacement Kit	1
1	125500-2	3/4 inch Rotor/Support Replacement Kit	1
1	125500-3	1 inch Rotor/Support Replacement Kit	1
1	125500-4	1-1/2 inch Rotor/Support Replacement Kit	1
1	125500-5	2 inch Rotor/Support Replacement Kit	1
2	904005-20	One 1/2 inch Retaining Ring	2
2	904005-21	One 3/4 inch Retaining Ring	2
2	904005-22	One 1 inch Retaining Ring	2
2	904005-23	One 1-1/2 inch Retaining Ring	2
2	904005-24	One 2 inch Retaining Ring	2
	901003-1	Bottom Coverplate O-Ring (not shown)	1
3	901003-35	Gasket - 3/4 inch Fluoroelastomer	2
3	901003-36	Gasket - 1 inch Fluoroelastomer	2
3	901003-37	Gasket - 1-1/2 inch Fluoroelastomer	2
3	901003-38	Gasket - 2 inch Fluoroelastomer	2
3	901003-39	Gasket - 2-1/2 inch Fluoroelastomer	2
3	901003-40	Gasket - 3/4 inch Nitrile	2
3	901003-41	Gasket - 1 inch Nitrile	2
3	901003-42	Gasket - 1-1/2 inch Nitrile	2
3	901003-43	Gasket - 2 inch Nitrile	2
3	901003-44	Gasket - 2-1/2 inch Nitrile	2
4	906005-49	Clamp - 3/4 inch	2
4	906005-50	Clamp - 1 inch	2
4	906005-50	Clamp - 1-1/2 inch	2
4	906005-51	Clamp - 2 inch	2
4	906005-52	Clamp - 2-1/2 inch	2

SERVICE

For warranty consideration, parts, or other service information, please contact your local distributor. If you need further assistance, call the GPI Customer Service Department in Wichita, Kansas, during normal business hours.

1-888-996-3837

To obtain prompt, efficient service, always be prepared with the following information:

1. The model number of your turbine.
2. The serial number or manufacturing date code of your turbine.
3. Specific information about part numbers and descriptions.

For warranty work always be prepared with your original sales slip or other evidence of purchase date.

Returning Parts

Please contact the factory before returning any parts. It may be possible to diagnose the trouble and identify needed parts in a telephone call. GPI can also inform you of any special handling requirements you will need to follow covering the transportation and handling of equipment which has been used to transfer hazardous or flammable liquids.

⚠ CAUTION

Turbines not flushed before shipment can be refused and returned to the sender.

⚠ CAUTION

Do not return turbines without specific authority from the GPI Customer Service Department. Due to strict regulations governing transportation, handling, and disposal of hazardous or flammable liquids, GPI will not accept turbines for rework unless they are completely free of liquid residue.

Limited Warranty Policy

Great Plains Industries, Inc. 5252 E. 36th Street North, Wichita, KS USA 67220-3205, hereby provides a limited warranty against defects in material and workmanship on all products manufactured by Great Plains Industries, Inc. This product includes a 1 year warranty. Manufacturer's sole obligation under the foregoing warranties will be limited to either, at Manufacturer's option, replacing or repairing defective Goods (subject to limitations hereinafter provided) or refunding the purchase price for such Goods theretofore paid by the Buyer, and Buyer's exclusive remedy for breach of any such warranties will be enforcement of such obligations of Manufacturer. The warranty shall extend to the purchaser of this product and to any person to whom such product is transferred during the warranty period.

The warranty period shall begin on the date of manufacture or on the date of purchase with an original sales receipt. This warranty shall not apply if:

- A. the product has been altered or modified outside the warrantor's duly appointed representative;
- B. the product has been subjected to neglect, misuse, abuse or damage or has been installed or operated other than in accordance with the manufacturer's operating instructions.

To make a claim against this warranty, contact the GPI Customer Service Department at 316-686-7361 or 888-996-3837. Or by mail at:

Great Plains Industries, Inc.
5252 E. 36th St. North
Wichita, KS, USA 67220-3205

If you are outside North or South America contact:

Great Plains Industries – Australia
1/16 Atkinson Road,
Taren Point NSW 2229, Sydney, Australia

The company shall, notify the customer to either send the product, transportation prepaid, to the company at its office in Wichita, Kansas, or to a duly authorized service center. The company shall perform all obligations imposed on it by the terms of this warranty within 60 days of receipt of the defective product.

GREAT PLAINS INDUSTRIES, INC., EXCLUDES LIABILITY UNDER THIS WARRANTY FOR DIRECT, INDIRECT, INCIDENTAL AND CONSEQUENTIAL DAMAGES INCURRED IN THE USE OR LOSS OF USE OF THE PRODUCT WARRANTED HEREUNDER.

The company herewith expressly disclaims any warranty of merchantability or fitness for any particular purpose other than for which it was designed.

This warranty gives you specific rights and you may also have other rights which vary from U.S. state to U.S. state.

Note: In compliance with MAGNUSON MOSS CONSUMER WARRANTY ACT – Part 702 (governs the resale availability of the warranty terms).



ATEX



(IP65)

Wichita · Sydney · Mexico City

GREAT PLAINS INDUSTRIES



Great Plains Industries, Inc. / 888-996-3837 / GPI.net